

Reliable®

Model F1FR56-300 Series 300 psi (20,7 bar) Rated Quick Response Standard Spray

Model F1FR56-300

Sprinkler Types

- Upright
- Pendent
- Horizontal Sidewall
- Recessed Pendent F1/F2/FP
- Recessed Horizontal Sidewall
- Concealed Pendent
- SWC56 Sidewall Concealed

Listings & Approvals

1. Listed by Underwriters Laboratories, Inc. and Certified for Canada (cULus)

UL Listing Category

Sprinklers, Automatic & Open
Quick Response Sprinklers (VNIV)

Product Description

F1FR56-300 Upright, Pendent, Recessed Pendent, and Concealed Pendent

Reliable Models F1FR56-300 QR Upright, Pendent and Recessed Pendent Sprinklers are high pressure rated automatic sprinklers which can handle a maximum service pressure of 300 psi (20,7 bar).

The Reliable Model F1FR56-300/CCP Quick Response Concealed Sprinkler is an attractive, low profile concealed sprinkler assembly. This sprinkler assembly utilizes a Model F1FR56-300 pendent sprinkler in a Model CCP cup and cover plate assembly. The cup is securely factory threaded on the sprinkler inlet end. The assembly is shipped with a protective cap. The sprinkler and cup are easily installed into the drop nipple using the Model RC1 Sprinkler Wrench. The cover plate assembly is attached to the sprinkler cup using a cover plate assembly with flexible tabs for threaded engagement. Simply push on the cover plate, then turn to adjust or remove the cover plate assembly.

The cover plate is attached to the skirt using 135°F (57°C) or 165°F (74°C) ordinary temperature classification solder. When the ceiling temperature rises, the solder holding the cover plate melts, allowing the release of this part and thus exposing the Model F1FR56-300 sprinkler inside to the rising ambient temperature.



Upright

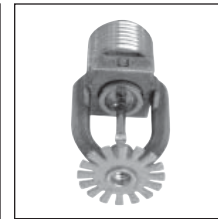

Pendent

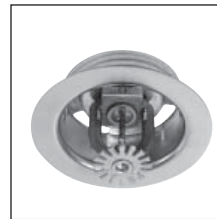
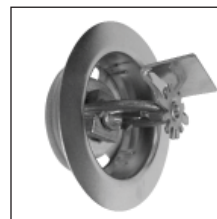
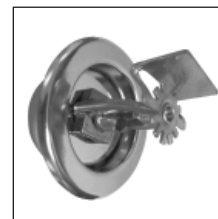

Horizontal Sidewall

Recessed
Pendent/FPRecessed
Pendent/F1 & F2Concealed
PendentRecessed FP
Horizontal SidewallRecessed F1 & F2
Horizontal SidewallSWC56
Sidewall Concealed

These automatic sprinklers are quick response sprinklers which utilize a 3.0mm frangible glass bulb. They have demonstrated response times in laboratory tests which are five to ten times faster than standard response sprinklers. This quick response enables Model F1FR56-300 sprinklers to apply water to a fire much faster than standard response sprinklers of the same temperature rating.

The glass bulb contains an accurately controlled amount of special fluid hermetically sealed inside. The other sprinkler parts are made of brass, copper or beryllium nickel.

At normal temperatures, the glass bulb contains fluid in both the liquid and vapor phases. The vapor phase can be seen as a small bubble. As heat is applied, the liquid expands, forcing the bubble smaller and smaller as the liquid pressure increases. Continued heating forces the liquid to push out against the bulb, causing the glass to shatter, opening the waterway and allowing the deflector to distribute the discharging water.

The temperature rating of the sprinkler is identified by the color of the glass bulb.

Model F1FR56-300 Quick Response Upright and Pendent Sprinkler

Installation Wrench: Model D Sprinkler Wrench

Installation Data:

Sprinkler Type	Nominal Orifice Size	Thread Size	Nominal K Factor		Sprinkler Height	Sprinkler Identification Number (SIN)
			US	Metric		
Upright	½"(15mm)	½" NPT (R½)	5.6	80	2.2"(56mm)	RA2625 ⁽¹⁾
Pendent	½" (15mm)	½" NPT (R½)	5.6	80	2.2"(56mm)	RA2614 ⁽¹⁾

⁽¹⁾ cULus Listed corrosion resistant (Polyester coated) sprinkler.



Upright



Pendent

Model F1FR56-300 Quick Response Recessed Pendent Sprinkler

Installation Wrench: Model GFR2 Sprinkler Wrench

Installation Data:

Sprinkler Type	Nominal Orifice Size	Thread Size	Nominal K Factor		Sprinkler Height	Sprinkler Identification Number (SIN)
			US	Metric		
Recessed Pendent	½" (15mm)	½" NPT (R½)	5.6	80	2.25"(57mm)	RA2614

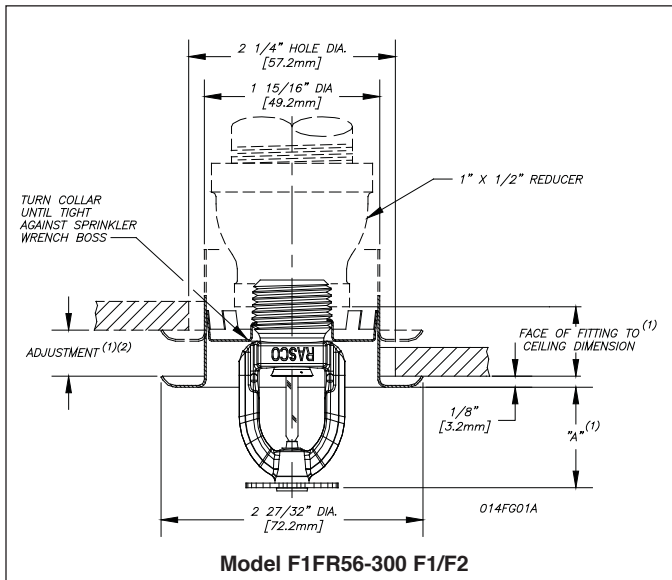

Fig. 1

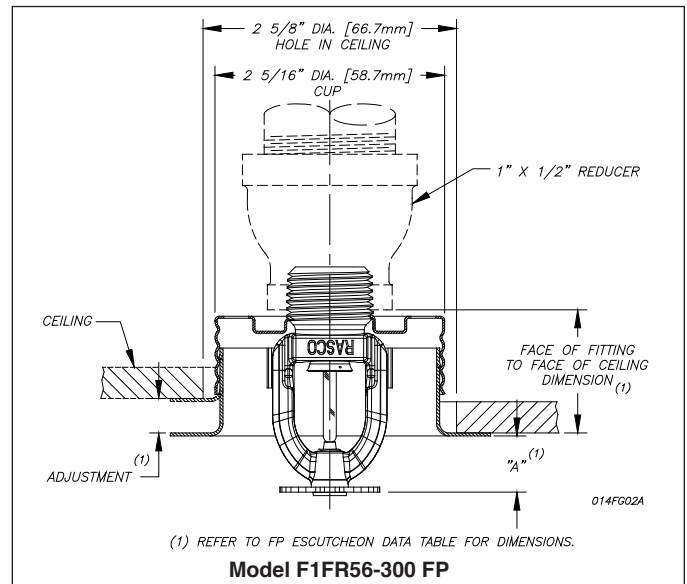

Fig. 2

⁽¹⁾ Refer to escutcheon data table for dimensions.

⁽²⁾ When installed directly into a tee, the escutcheon adjustment will be reduced.

Model F1FR56-300 Quick Response Concealed Pendent Sprinkler (CCP)

Installation Wrench: Model RC1 Sprinkler Wrench

Technical Data:

Nominal Orifice Size	Thread Size	Nominal K Factor		Temp. Rating		Max. Ambient Temp.	Bulb Color	Sprinkler Identification Number (SIN)
		US	Metric	Sprinkler	Cover			
1/2" (15mm)	1/2" NPT (R1/2)	5.6	80	135°F/57°C	135°F/57°C	100°F/38°C	Orange	RA2614
1/2" (15mm)	1/2" NPT (R1/2)	5.6	80	155°F/68°C	135°F/57°C	100°F/38°C	Red	
1/2" (15mm)	1/2" NPT (R1/2)	5.6	80	175°F/79°C	165°F/74°C	150°F/66°C	Yellow	
1/2" (15mm)	1/2" NPT (R1/2)	5.6	80	200°F/93°C	165°F/74°C	150°F/66°C	Green	

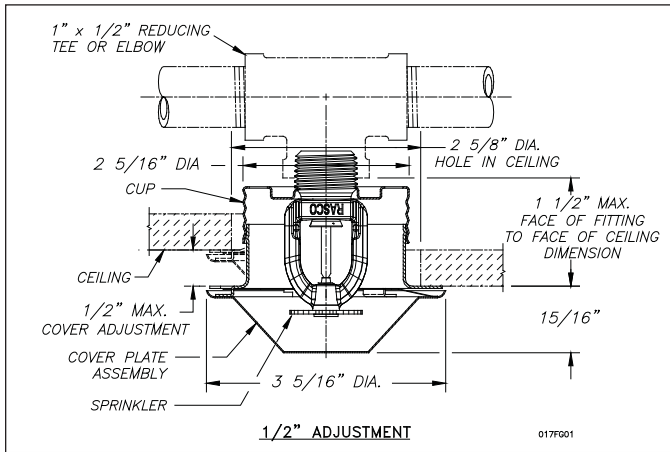

Fig. 3

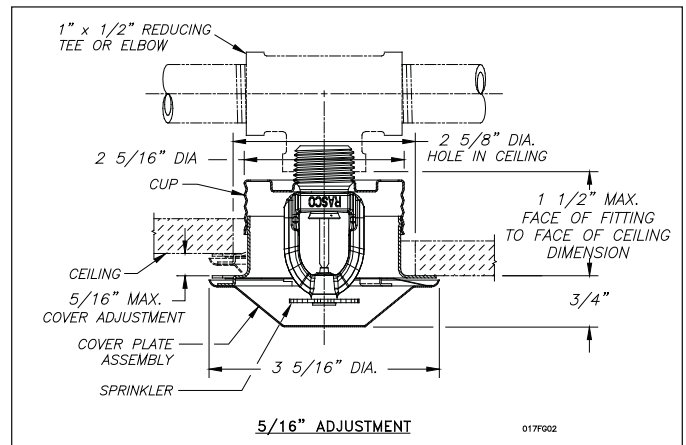

Fig. 4

Model F1FR56-300 Quick Response Recessed and SWC56 Sidewall Concealed Sprinkler

Installation Wrench: Use Model GFR2 Wrench for Concealed and Recessed sprinklers.

Use Model D Wrench for Horizontal Sidewall sprinklers.

Technical Data:

Nominal Orifice Size	Thread Size	K Factor		Sprinkler Identification Number (SIN)
		US	Metric	
1/2" (15mm)	1/2" NPT (R1/2)	5.6	80	RA2634 ⁽¹⁾

⁽¹⁾ cULus Listed corrosion resistant (Polyester coated) sprinkler.

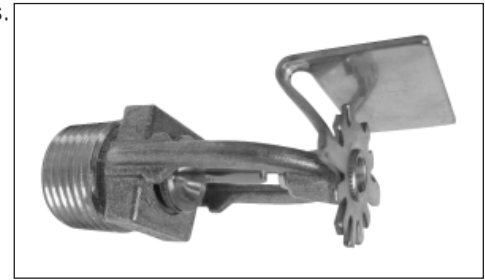

Horizontal Sidewall

Features:

1. Deflector to ceiling dimensions are: 4" (102mm) min. to 12" (305mm) max. Minimum spacing between sprinklers - 6 feet (2.4m).
2. UL Listed for light & ordinary hazard applications.
3. No exposed thermal element with the concealed version. Tamper resistant cover plate can prevent the sprinkler from being used for unintended purposes.
4. FP push-on/thread-off or standard friction fit F2 escutcheon.
5. Factory assembled sprinkler & cup, shipped complete with protective cap.
6. 1/2" (13mm) adjustment of both escutcheons and cover.
7. Cover available in standard white paint, special bronze, black paint or flat white finishes.
8. Quick response standard coverage.
9. Approved for installation in accordance with NFPA 13 for Light & Ordinary Hazard occupancies.

Installation Aid

A protective plastic cap is included for use during installation.

Escutcheon Data:

FP cup/escutcheon assembly - 1/2" (13mm) adjustment.

F2 collar & escutcheon 1/2" (13mm) adjustment

Patents: U.S. No. 6,374,919 Applies to Concealed Sprinklers

Technical Data:

K Factor		Thread Size	Temperature Rating		Maximum Ambient Temperature	Sprinkler Identification Number (SIN)
US	Metric		Sprinkler	Cover		
5.6	80	1/2"	155°F (68°C) 135°F (57°C)	135°F (57°C)	100°F (38°C)	RA2634

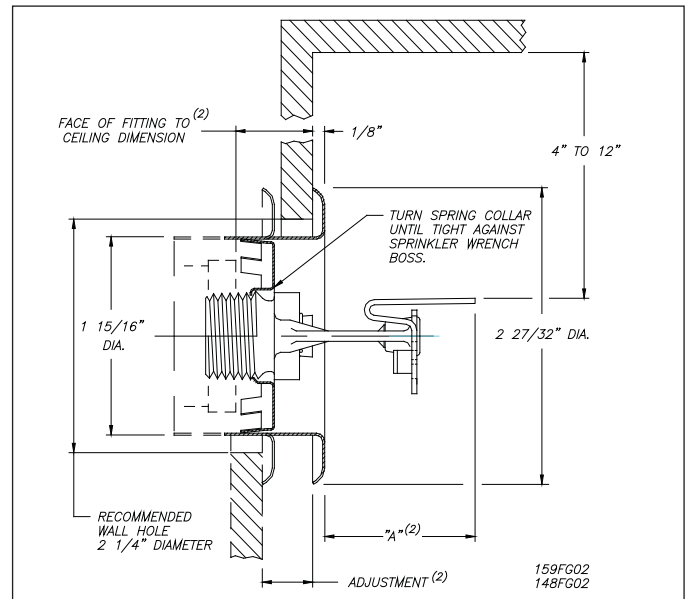

⁽²⁾ Refer to escutcheon data for dimensions.

Fig. 5

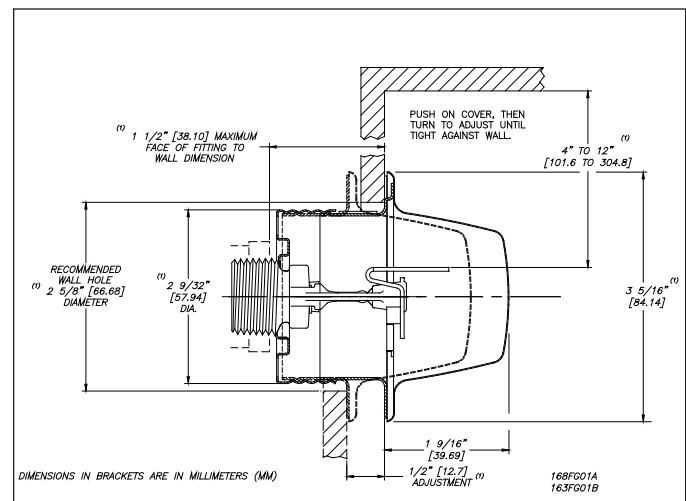

⁽¹⁾ Dimensions are common for Recessed sprinkler and SWC56 Concealed sprinkler

Fig. 6

F1FR56-300 Horizontal Sidewall, F1FR56-300 Horizontal Sidewall Recessed & F1FR56-300 Horizontal Sidewall Concealed

Models F1FR56-300 Horizontal Sidewall, F1FR56-300 Horizontal Sidewall Recessed and SWC56 Concealed are quick response type sprinklers. Model F1FR56-300 Horizontal Sidewall Recessed and SWC56 assemblies utilize the push-on / thread-off escutcheon and cover-plate, respectively. These assemblies are shipped with a protective cap. Remove cap to enable mounting the F1FR56-300 Horizontal Sidewall sprinkler/cup assembly in place and then push or thread the escutcheon or cover-plate into the installed sprinkler/cup assembly. When the F1FR56-300 Horizontal Sidewall is ordered with the F2 escutcheon the sprinkler and escutcheon assembly are shipped separately. The sprinkler and collar must be assembled together before the sprinkler can be installed in a fitting.

The SWC56 sprinkler's cover is attached to its skirt using 135°F (57°C) ordinary temperature classification solder. When the ambient temperature rises, the solder holding the cover-plate melts, allowing the release of this part and thus exposing the sprinkler inside to the rising ambient temperature.

The Model F1FR56-300 Horizontal Sidewall utilizes a 3.0mm frangible glass bulb. This allows quick response which enables the sprinkler to apply water to a fire sooner than standard sprinklers of the same temperature rating.

Application and Installation

The most common applications for Model F1FR56-300 Series Quick Response Sprinklers will be in fire protection systems for high rise buildings where a quick response rating is required and the pressure entering the sprinkler system is in excess of 175 psi (12 bar). The use of these sprinklers will provide opportunity to reduce or eliminate the need for pressure reducing valves.

The Model F1FR56-300/CCP Concealed Sprinkler Assembly uses a 1/2" (15mm) orifice, 1/2" NPT (R1/2), 135°F (57°C), 155°F (68°C), 175°F (79°C), or 200°F (93°C) rated Model F1FR56-300 Pendent Sprinkler with a threaded Model CCP cup, which is factory attached to the sprinkler. The assembly is completed by the installation of an attractive, low profile, 135°F (57°C) or 165°F (74°C) rated Model CCP push on cover plate assembly. The cover plate and sprinkler cup assemblies are joined using a cover plate with flexible tabs for threaded engagement. A choice of two cover plate assemblies provide either 1/2" (13mm) or 5/16" (8mm) of cover adjustment.

Do not install these sprinklers in ceiling which have positive pressure in the space above.

After a 2⁵/₈" (67mm) diameter hole is cut in the ceiling, the sprinkler is easily installed with the Model RC1 Wrench. A Teflon*-based thread sealant should be applied to the sprinkler threads only. The Model RC1 Wrench is then used to engage the sprinkler wrenching surfaces and to install the sprinkler in the fitting. When inserting or removing the wrench from the sprinkler/cup assembly, DO NOT WRENCH ON ANY OTHER

PART OF THE SPRINKLER. The cover plate is then pushed onto the cup. Final adjustment is made by hand turning the cover plate until the skirt flange makes full contact with the ceiling. Cover plate removal requires turning in the counter clockwise direction.

After installation, inspect all sprinklers to ensure that there is a gap between the cover plate and ceiling and that the four cup slots are open and free from any air flow impediment to the space above.

Concealed cover plate/cup assemblies are listed only for use on specific sprinklers. The use of any other concealed cover plate/cup assembly with the Model F1FR56-300 Pendent Sprinkler or the use of the Model CCP concealed cover plate assembly on any sprinkler with which it is not specifically listed may prevent good fire protection and will void all guarantees, warranties, listings and approvals.

Quick response sprinklers are intended for installation as specified in NFPA 13. Quick response sprinklers and standard response sprinklers should not be intermixed.

The Model F1FR Series Recessed and Concealed Quick Response Sprinklers are to be installed as shown.

When installing Model F1FR56-300 Upright and Pendent Sprinklers, use the Model D Sprinkler Wrench. Use the Model GFR2 Wrench for installing F1FR-300 Recessed and Concealed Pendent Sprinklers. Any other type of wrench may damage these sprinklers.

Glass bulb sprinklers have orange covers to protect the bulb during the installation process. REMOVE THIS PROTECTION ONLY AFTER THE SYSTEM HAS BEEN HYDROSTATICALLY TESTED AND, WHEN APPLICABLE, THE ESCUTCHEONS HAVE BEEN INSTALLED. RASCO wrenches are designed to install sprinklers when covers are in place.

The Model F1FR56-300 Horizontal Sidewall sprinkler is intended for installation in light & ordinary hazard occupancies in accordance with NFPA 13. This sprinkler is especially well-suited for use in student dormitories, hotels, hospitals and care facilities, and can be used where the pressure entering the sprinkler system calls for 300 psi (20,7 bar) applications.

Models F1FR56-300 Horizontal Sidewall recessed and SWC56 concealed sprinklers utilize a threaded cup which is factory attached to the sprinkler. The assembly is completed by the installation of the attractive push-on/thread-off escutcheon and 135°F (57°C) rated push-on/thread-off cover, respectively. When the F1FR56-300 Horizontal Sidewall is ordered with the F2 escutcheon the escutcheon assembly is shipped separately and requires assembly of the collar at the time of installation (Ref. Figure 4).

Apply a Teflon*-based thread sealant to the sprinkler threads. After a 2⁵/₈" (67mm) diameter hole is cut in the wall, the sprinkler is easily installed with the Model GFR2 Wrench. To install the sprinkler, remove the protective cap and then position the wrench into the sprinkler/cup assembly until the wrench fully engages the flats of the sprinkler. Then tighten the sprinkler into the pipe fitting. When inserting or removing the wrench from the sprinkler/cup assembly, care should be taken to prevent damage to the sprinkler. DO NOT WRENCH ON ANY OTHER PART OF THE SPRINKLER.

*DuPont Registered Trade Mark

Protective plastic caps must be replaced on sprinklers after they are installed and must remain on sprinklers until covers or escutcheons are installed. The escutcheon or cover-plate assembly is installed by either pushing or threading into the cup. FP escutcheons and cover assemblies provide 1/2" (13mm) of adjustment. Final adjustment is made by turning clockwise until the flange makes full contact with the wall surface. Escutcheon or cover removal requires turning in the counter-clockwise direction.

Covers and recessed escutcheons described in this bulletin are listed only for use with specific sprinklers. The use of any other cover or escutcheon, with the Model F1FR56-300 Horizontal Sidewall Sprinkler or the use of the cover assembly or escutcheons on any sprinkler with which they are not specifically listed will void all guarantees, warranties, listings and approvals.

When installing Model F1FR56-300 Horizontal Sidewall sprinklers with raised escutcheons use a Model D wrench. The protective plastic wraps on these sprinklers should remain on them throughout the installation. When the sprinkler system is placed in service, the wraps must be removed.

Maintenance

Model F1FR56-300 Series Sprinklers should be inspected quarterly and the sprinkler system maintained in accordance with NFPA 25. Do not clean sprinklers with soap and water, ammonia or any other cleaning fluids. Remove dust by using a soft brush or gentle vacuuming. Remove any sprinkler that has been painted (other than factory applied) or damaged in any way. A stock of spare sprinklers should be maintained to allow quick replacement of damaged or operated sprinklers. Prior to installation, sprinklers should be maintained in the original cartons and packaging until used to minimize the potential for damage to sprinklers that would cause improper operation or non-operation.

Ordering Information.

Models F1FR56-300 Horizontal Sidewall, F1FR56-300 Horizontal Sidewall recessed and SWC56 concealed sprinklers should be inspected quarterly and the sprinkler maintained in accordance with NFPA 25. Do not clean sprinklers with soap and water, ammonia or any other cleaning fluids. Remove dust by using a soft brush or gentle vacuuming. Remove any sprinkler/cover assembly, which has been painted (other than factory applied) or damaged in any way. A stock of spare sprinklers should be maintained to allow quick replacement of damaged or operated sprinklers. Prior to installation, sprinklers should be maintained in their original cartons and packaging until used to minimize the potential for damage to sprinklers that would cause improper operation or non-operation.

Escutcheon Data

Escutcheon Model	Adjustment	"A" Dimension	Face of Fitting to Ceiling or Wall Dimension
F1	Max Recess Min Recess	1 1/2" (38.1mm) 3/4" (19.1mm)	3/16" - 15/16" (5mm - 24mm)
F2	Max Recess Min Recess	1 1/2" (38.1mm) 1" (25mm)	3/16" - 11/16" (5mm - 17mm)
FP Push-on/ Thread-off	Max Recessed Min Recessed	7/16" (11mm) 15/16" (24mm)	1 1/2" (38.1mm) 1" (25.4mm)

Standard Temperature Rating

Classification	Sprinkler Temperature		Maximum Ambient Temp.		Bulb Color
	°F	°C	°F	°C	
Ordinary	135	57	100	38	Orange
Ordinary	155	68	100	38	Red
Intermediate	175	79	150	66	Yellow
Intermediate	200	93	150	66	Green
High ⁽¹⁾	286	141	225	107	Blue

⁽¹⁾ Not available for recessed or concealed sprinklers, available on all Models except the Horizontal Sidewall.

Maximum Working Pressure

300 psi (20.7 bar)

100% Factory tested hydrostatically to 600 psi (41.4 bar)

Finishes ⁽¹⁾

Standard Finishes		
Sprinkler	Escutcheon	Cover Plates
Bronze Chrome Plated Polyester Coated ⁽²⁾	Brass Bright Chrome Plated White Painted	White Painted Chrome
Special Applications Finishes		
Sprinkler	Escutcheon	Cover Plates
Bright Brass Black Plated Black Paint Off White Satin Chrome	Bright Brass Black Plated Black Paint Off White Satin Chrome	Bright Brass Black Plated Black Paint Off White

⁽¹⁾ Other colors and finishes are available on special order. Consult factory for details.

⁽²⁾ cULus Listed "Corrosion Resistant" applies to SIN RA2614 (Pendent), RA2625 (Upright) and RA2634 (HSW) in Standard Black or White.

Note: Paint or any other coating applied over the factory finish will void approvals and warranties.

Ordering Information

Specify:

1. Sprinkler Model
2. Sprinkler Type
3. Orifice Size
4. Deflector Type
5. Temperature Rating
6. Sprinkler Finish
7. Escutcheon Finish (where applicable)
8. Coverplate Finish (where applicable)

Note: When Model F1FR56-300 Series Recessed sprinklers are ordered, the sprinklers, escutcheons and coverplates are packaged separately.

The equipment presented in this bulletin is to be installed in accordance with the latest published Standards of the National Fire Protection Association, Factory Mutual Research Corporation, or other similar organizations and also with the provisions of governmental codes or ordinances whenever applicable. Products manufactured and distributed by Reliable have been protecting life and property for over 90 years, and are installed and serviced by the most highly qualified and reputable sprinkler contractors located throughout the United States, Canada and foreign countries.

Manufactured by

Reliable®

The Reliable Automatic Sprinkler Co., Inc.
 (800) 431-1588 Sales Offices
 (800) 848-6051 Sales Fax
 (914) 829-2042 Corporate Offices
 www.reliablesprinkler.com Internet Address



Revision lines indicate updated or new data.

EG. Printed in U.S.A 11/12 P/N 9999970386